

# MINIFLOW 600 EVO

## HORIZONTAL MINI FLOW WRAP MACHINE

Mini flow wrap machine suitable for baked goods, pharmaceuticals and various objects.



## DESCRIPTION

---

**Miniflow 600 EVO** is **minipack®-torre's** new **horizontal flow wrap machine**.

A high performance, versatile, technologically advanced flow wrap machine aimed at businesses that are looking for a high-quality product to optimize their packaging processes with a high level of performance.

**minipack®-torre S.p.A.**

Sede legale - Via Provinciale, 54 - 24044 DALMINE (BG) Italy

P.IVA - C.F.: 01633550163 - Capitale sociale 619.200,00 i.v. - Reg. Imprese di Bergamo 01633550163 - REA n. 224151

This **mini flow wrap machine** is designed to simplify customers' maintenance and cleaning operations as much as possible.

Thanks to its **3 high-performance brushless** motors and its **7" touch screen panel**, the **horizontal flow wrapper** guarantees **maximum versatility in changing format**, therefore packaging operations become extremely simple. It can package a range of products to a **maximum of 600 mm** and at a rate of up to **120 products per minute**.

## Why choose a mini flow pack machine by minipack®-torre?

With an excellent quality-price ratio, this mini flow pack machine is a mix of quality and technology and guarantees high reliability. It is suitable for packaging innumerable food and non-food products like croissants, cakes, pharmaceuticals, toffees, chocolates, chocolate bars, various small objects and lots more besides.

## TECHNICAL FEATURES

Power supply	V	220
Pneumatic supply	Bar	6
Electrical power	KW	3,5
Electric consumption	KW	3,5
Hourly production p/h	p/h (pph)	0.7200
Sealing Bar	mm	300
MAX product weight	gr	1500
MAX product height	mm	110
MAX length product	mm	650
Reel Diameter MAX Dimensions	mm	350
MAX Reel Strip Dimensions	mm	600
Worktop height	mm	950
Machine dimensions	mm	3300 x 1150 x h1750
Machine weight	kg	700

### minipack®-torre S.p.A.

Sede legale - Via Provinciale, 54 - 24044 DALMINE (BG) Italy

P.IVA - C.F.: 01633550163 - Capitale sociale 619.200,00 i.v. - Reg. Imprese di Bergamo 01633550163 - REA n. 224151

minipack®-torre shall not be held liable for typos or printing errors in this catalogue. It also reserves the right to make changes to the specified features without prior notice. All trademarks are property of their respective owners and are hereby acknowledged.

## TECHNICAL DRAWING

---

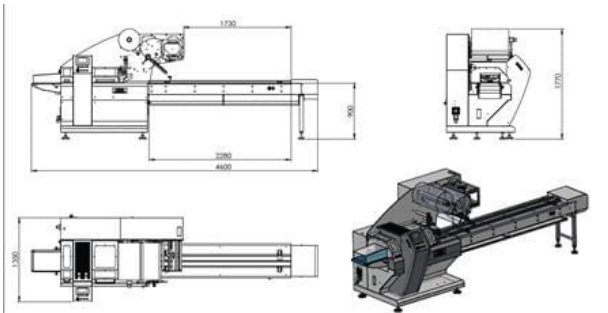

## CHARACTERISTICS:

---

- User-friendly 7" PLC touch screen
- Easy inspection for maintenance and cleaning of roller unit
- Expandable pneumatic shaft for film support
- 3 brushless motors
- Photocell to centre printed film
- 3 pairs of infeed rollers - last group with a folding fin function
- Infeed roller with integrated pneumatic opening
- Safety housing, with stoppage system in the event of opening
- EC certified safety and management modules
- Motorised product unloading belt with central guide
- Emergency button with immediate interruption of the production cycle
- Inspectable magnetic roller bars
- Sliding surface in AISI 304 stainless steel conforming with EC regulations
- "Crumb catcher" boxes on the infeed belt
- Rotating collectors with integrated brushes
- Parameter and recipe backup via USB port
- Belt handling mechanism to reduce play
- Network connection for assistance via LAN and VNC L cable