

# MOSCA<sup>®</sup>

EXCELLENCE IN STRAPPING SOLUTIONS

## EVOLUTION



**SONIXs MP-6 R-VA**  
Fully Automatic Stainless Steel  
Strapping Machine

## SoniXs MP-6 R-VA

### STANDARD FEATURES

- Corrosion-resistant ultrasonic sealing system with electronic self-calibration
- High-end Standard 6 sealing unit
- Easy accessibility and tool-free disassembly of strap path components
- Wear-free DC drives with integrated electronics
- Stepless turnable control panel for many-sided operation
- Adjustable strap tension via control panel
- Switching from maximum to material-friendly Eco-speed in the control
- Quick strap coil change
- Strap coil changeable from the front and the side
- Automatic strap threading system
- Strap end detection with ejection of remaining strap
- Automatic strap loop ejection
- Extremely low energy consumption
- 4 castors, 2 of them lockable (Ø 80 mm)
- CE marking inclusive conformity declaration
- Potential-free contacts to upstream and downstream machines
- Continuously adjustable conveyorspeed from 0-1 m/s
- Parameter control panel for setting strapping parameters

- Selector switch for pass, single, double or multiple strapping
- Machine completely corrosion-resistant (main use of V4A stainless steel)
- IP 56 protection class design
- Sensitive components (e.g. motors) are equipped with additional covers

### OPTIONS

- Pneumatic hold-down device
- Automatic adjustment of the strap tension by package height detection
- Safety pop-up roll at table in- and outfeed
- Product cover identification device (no strapping without top cover)
- Brush guide
- Low strap detection with signal in the control panel
- Signal light
- Emergency stop interface

### TECHNICAL DATA

**PERFORMANCE:** Up to 35 cycles/ minute

**FRAME SIZE (WxH):** 600 mm x 600 mm

### WORKING HEIGHTS:

820 mm to 925 mm  
 730 mm to 835 mm (optionally lower working height)  
 820 mm to 1025 mm (optionally increased working height)

### STRAPS:

Standard machine PP straps: Width 5 - 12 mm  
 Thickness 0.4 - 0.63 mm

### STRAP COIL DISPENSER:

Core diameter: 200 mm  
 Core width: 190 mm  
 Max. outer diameter: 430 mm

### ELECTRICITY:

Voltage: 100-240V, 50/60 Hz,  
 1L+N+PE  
 Power consumption: approx. 0.25 kW

### WEIGHT:

260 kg

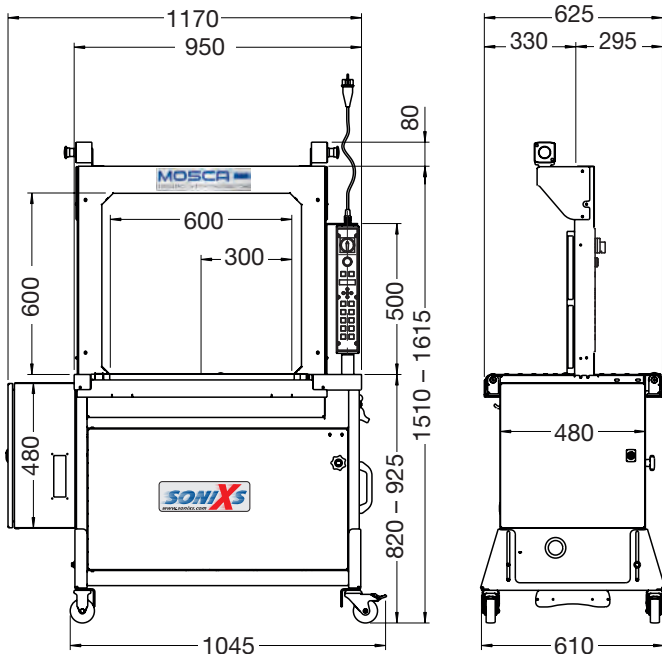

**MOSCA®**  
 EXCELLENCE IN STRAPPING SOLUTIONS

#### MOSCA GMBH

Gerd-Mosca-Straße 1  
 D-69429 Waldbrunn/Germany  
 Tel.: +49 6274/932-0  
 Fax: +49 6274/932-400 118  
 Tel. Tech. Service: +49 6274 / 932-146  
 E-Mail: info@mosca.com  
 Internet: www.mosca.com

03/20 Subject to alterations



The models of SoniXs MP-6 R-VA are adjustable to one strap width of 5, 6, 8, 9, 10 or 12 mm quality PP straps. Obtainable directly from Mosca, produced in one of Europe's most modern manufacturing plants. Combinable with maintenance contracts by Mosca – a one-stop solution.

