



BeeWrap

Pre-Stretch >>>> Productivity >>>> Robustness >>>>

DATASHEET

SAFE • STRONG • SIMPLE

Semi-Automatic Robot Stretch-Wrapper

BeeWrap is a mobile wrapping machine used for palletizing goods with stretch film. It is suitable for heavy weight items, unusual shapes and loads with large dimensions. It is equipped with a digital control panel that allows the user, in an easy and functional way, to alter various parameters and set-up customized wrapping cycle programs.

KEY FEATURES

- ✓ **Safety First** – BeeWrap incorporates several safety features as standard
- ✓ **No film waste** – with motorized Pre-Stretch system & independent tension control
- ✓ **Increased production capacity** – thanks to customized settings
- ✓ **Versatile use** – suitable for very large and round loads
- ✓ **Flexibility** – Machine is easily moved to various locations
- ✓ **Modular system** – meeting your individual needs
- ✓ **Easy-to-use** – due to the simple control concept
- ✓ **CE compliant** - engineered and produced in Italy according to EU safety standards

DIMENSIONS

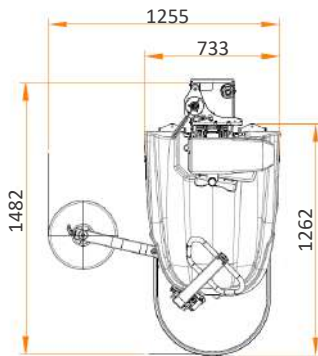

Version BeeWrap – L – M
 Depending on version, equipment and options, the machine dimensions may differ.

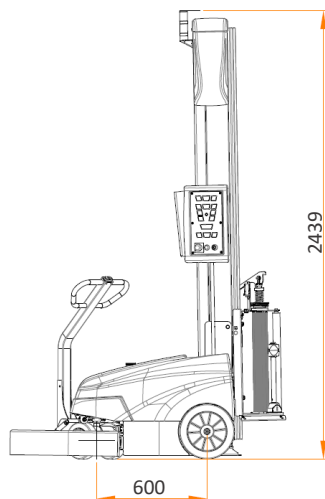
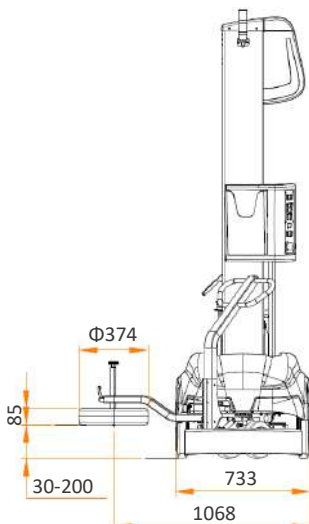

DATASHEET

Carriage type	LP	FM	M
Description	Powered Pre-Stretch	Electro-Magnetic Brake	Mechanical Brake incl. quick release
Pre-Stretch level (%)	240 / 200	-	-
Max. pallet height (mm) incl. overlap above pallet top edge	2.100 std. (Low) / 2.600 (Medium)		
Pallet size (mm)	min. 400 x 500 / max. 6.000 x 7.000		
Min. pallet weight (kg)	20 – 55 (depending on film tension and friction)		
Power supply	100 – 240 V (via on-board charger)		
Rotation speed (m/min)	50 – 80 (adjustable)		
Max. noise level	72,0 dB(A)		
Operating temperature	5 – 40°C		
Film roll details (max.)	width 500 mm / ext. Φ 300 mm / core Φ 76mm (fix) / weight 20 kg / thickness up to 35 micron		
Features	LP	FM	M
4 Automatic modes	•	•	•
9 + 1 individual programs	•	•	•
Pre-Stretch system	•	-	-
Adjustable film tension from control panel	•	•	-
Adjustable tracing wheel	•	•	•
Independent setting of rotation & carriage speeds	•	•	•
Lockable Control Panel	•	•	•
Top-Sheet function	•	•	•
No. of Top- & Bottom windings (independent settable)	•	•	•
Automatic height detection*	•	•	•
Top edge overlap (settable from control-panel)	•	•	•
Adjustable bottom overlap	•	•	•
Auto. film break detection	•	-	-
Energy saving / Auto-Off	•	•	•

* for wrapping of loads with many open spaces, the height can be programmed instead of using the height detection

OPTIONS & ACCESSORIES

- Photocell for dark or reflective surfaces
- Film cutting punch (only on LP-carriage)
- Gel-batteries
- Carriage for net-film
- Double tracing wheel
- Remote control



NEEDED SPACE

Area required for machine rotation (not including safety area)

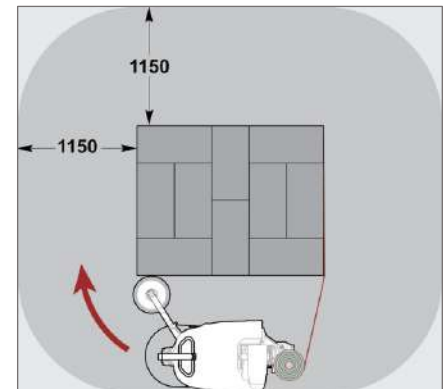

CONTROL PANEL



- User friendly icons and jog selector for quick parameter set-up
- 9 + 1 customizable programs
- Semi-automatic and manual working mode
- Individual Speeds for Up/Down carriage movement
- Separated set-up for top and bottom reinforcement wraps
- Emergency push-button according to regulations

BATTERY AND SAFETY

Standard lead-acid batteries allow up to 300 wrapped pallets per single charge*. Optional gel-batteries reduce the needed for additional maintenance.

Battery	
Type	Specification
Lead acid	2x 12V 90 Ah (C5)
Gel	2x 12V 105 Ah (C5)

* euro-pallet with 1,5 m height, up & down cycle incl. 2 top + 2 bottom wraps, film tension 10 daN

BeeWrap safety features include a beacon and klaxon during cycles and as well as a safety bumper with sensors which stop the unit immediately if contact is detected.



FILM CARRIAGES



MORE DETAILS

Videos and further information can be found on our website or SIAT Youtube channel.

